

Final Solve problems worth 100 points

10pt

- Will the following NFA accept strings that start with 0? Prove your answer by giving an example for a string starting with 0 that is accepted and one that is not accepted.

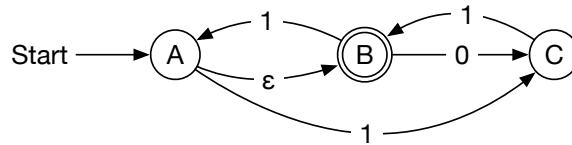

20pt

- Given the following code, (a) show that $\text{total} + x \cdot y = a \cdot b$ is a loop invariant of the while loop and (b) use the loop invariant to show that the function calculates the product correctly.

```

def mult(a,b):
    x = a
    y = b
    total = 0
    while x>0:
        if x%2 == 1:
            total = total + y
        x = x//2
        y = y*2
    return total
  
```

10pt
+
10pt

- Karatsuba's divide and conquer algorithm for multiplication breaks up the two operands (of length n) into two pieces each of size $n/2$ and uses three multiplications. This means that the recurrence for the multiplication of two operands of size n is given by

$$T(n) = 3T(n/2) + c.$$

The Master Theorem then tells us that $T(n) = \Theta(n^{\log_2(3)})$. Montgomery has found a formula for multiplication that breaks each operand into five pieces of size $n/5$ and using 23 multiplications. Give the recursion and the asymptotic behavior using Montgomery's method.

10pt

- Simultaneous min-max pairs up the elements of an array and then finds the maximum among the larger of the pairs and the minimum among the smaller of the pair. Evaluate instead the following algorithm: We divide the elements in the array into groups of three. (One group might have less than three elements). We use three comparisons in order to find the maximum and the minimum for each group of three. We then use $m - 1$ comparisons to find the minimum of the m minima of the groups of threes and the same number of comparisons for the maximum of the m maxima of the groups of three.
 - If n has remainder two after division with three, how many comparisons do we make? How do we compare with $2(n - 1)$ comparisons for the naïve algorithm?

10pt

5. A Linear Hash table has 50 buckets. What is its level and its split-pointer.

20pt

6. Give a dynamic programming solution to the following problem: You are given a set of integers in the range of $0 \dots k$ and a target T . You have to select a subset of the set of integers such that the sum of the integers is as close as possible to T .

30pt

7. Give a dynamic programming solution to the following problem: You are given a sequence of numbers. Find the largest contiguous subsequence that is strictly increasing.

8. We apply Floyd-Warshal to a small directed graph. The distance and the way-point matrix

$$\text{distance} = \begin{matrix} & 0 & 2 & 5 & 9 & 12 \\ & 100 & 0 & 3 & 7 & 10 \\ 100 & 9 & 0 & 4 & 7 & \\ 100 & 7 & 10 & 0 & 5 & \\ 100 & 2 & 5 & 9 & 0 & \end{matrix}$$

$$\text{predece} = \begin{matrix} & 0 & 1 & 1 & 2 & 2 \\ & -1 & 1 & 2 & 2 & 2 \\ -1 & 4 & 2 & 3 & 4 & \\ -1 & 4 & 4 & 3 & 4 & \\ -1 & 1 & 1 & 2 & 4 & \end{matrix}$$

are given by the following matrices. A distance of 100 indicates infinity and -1 indicates no way-point. What is the best way to go from Vertex 0 to Vertex 4?

10pt

9. A 0-1 knapsack problem has left us with the following table of weights and values and dynamic programming table:

	A	B	C	D	E	F	G	H	I	J
0 :	0	0	0	0	0	0	0	0	0	0
1 :	0	0	0	0	0	0	0	0	0	0
2 :	0	4	4	4	4	4	4	4	4	4
3 :	0	4	5	6	6	6	6	6	6	6
4 :	0	4	5	6	9	9	9	9	9	9
5 :	0	4	9	10	10	13	13	13	13	13
6 :	0	4	9	11	13	13	16	16	16	16
7 :	0	4	9	11	15	17	17	19	19	19
8 :	0	4	9	15	15	19	20	20	21	21
9 :	0	4	9	15	19	22	22	23	23	25
10 :	0	4	9	15	20	23	25	25	25	25
11 :	0	4	9	15	20	26	29	29	29	29
12 :	0	4	9	15	24	28	29	32	32	32
13 :	0	4	9	15	24	28	33	35	35	35
14 :	0	4	9	15	24	32	35	36	36	38
15 :	0	4	9	15	24	33	38	39	39	41
16 :	0	4	9	15	24	33	39	41	41	44
17 :	0	4	9	15	24	37	42	44	44	46
18 :	0	4	9	15	24	37	44	48	48	48
19 :	0	4	9	15	24	37	44	48	49	50
20 :	0	4	9	15	24	37	48	52	52	54
21 :	0	4	9	15	24	37	49	54	55	57
22 :	0	4	9	15	24	37	49	57	57	60
23 :	0	4	9	15	24	37	53	58	59	62
24 :	0	4	9	15	24	37	53	61	61	65
25 :	0	4	9	15	24	37	53	63	64	65

Item	A	B	C	D	E	F	G	H	I	J
Value	4	5	6	9	13	16	19	20	21	25
Weight	2	3	3	4	5	6	7	8	8	9

What is the best selection for a weight limit of 25?

- 10pt 10. Find an optimal Huffman encoding of the letters A, B, C, D, E, F if the frequencies of each letter are A: 5%, B: 40%, C:12%, D: 15%, E: 20% F: 8%.
- 10pt 11. In a directed graph, there is an edge of weight w from Vertex u to Vertex v . What relationship holds for the distances from another vertex s to u and to v ?
- 10pt 12. Assume that during the execution of DFS, we just painted Vertex u gray and start going through the adjacency list for Vertex u . We discover that Vertex v in the adjacency list of u is gray. Why does this imply that there is a cycle in the graph?
- 10pt 13. Is there an Eulerian circuit of the following graph?

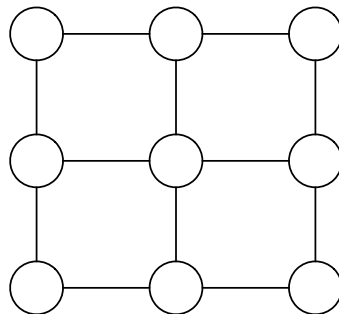

- 10pt 14. The execution of breadth first search on the following graph has reached the following state. What is the next step?

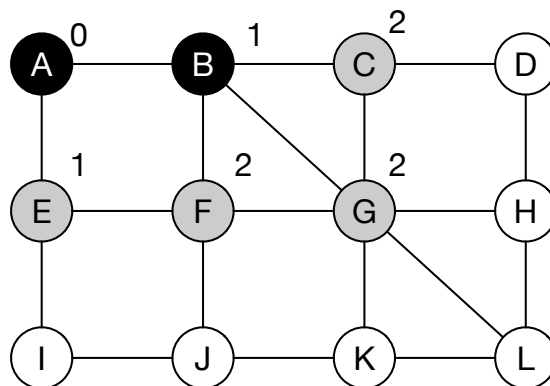

10pt

15. Is the "Halting Problem" in NP?

10pt

16. Assume I can show that if I can solve Problem A in polynomial time then I can solve Circuit Satisfiability in polynomial time. I can also show that I can verify a solution to Problem A in polynomial time. Why does this imply that Problem A is NP-complete.

17. What is the runtime of complete enumeration for the following edge coloring problem: You are given an undirected graph with v vertices, e edges, and a set of c colors. The task is to find a coloring of all of the edges with one of the $c > 1$ colors such that all edges adjoining any vertex are different. The complete enumeration algorithm (which can be implemented with back-tracking to skip over some configurations) tries each coloring for all edges. Is graph coloring in NP?

18. Show that no Hamiltonian path can exist for extremely sparse graphs (defined by the number of edges being less than half the number of vertices).

19. Construct a table of shifts for the pattern 'ACCACT' and the bad character rule in Boyers-Moore.